

SPECIAL REPORT FROM SI-1

TO SX

FROM SI-1

DTG 101310Z APR 95

SUBJ LARGE EXP IN HRASNICA ON 7 APR 95

1. AT 0840 HRS ON THE 7 APR 95 A VERY LARGE EXPLOSION OCCURED IN HRASNICA VILLAGE. THE IMPACT OCCURED AT GRID BP 8375 5278. DUE TO ROM A FULL INVESTIGATION WAS NOT POSSIBLE UNTIL NOW. A DIAGRAM OF THE IMPACT SIZE IS AT ANNEX A. AS A RESULT OF THE IMPACT 1X CIV FEMALE WAS KILLED AND 3X CIV FEMALES AND 1X CIV BOY WAS INJURED. THE CAS REPORT HAS BEEN SENT SEPERATELY.
2. THE WPN USED IS BELIEVED TO BE A HOMEMADE DEVICE CONSISTING OFF AN AIRCRAFT BOMB AND 4X 128mm M3RL ROCKETS. THE WPN WAS SUPPOSEDLY FIRED FROM AT TRUK IN THE RA OF ILIDZA AT GRID BP 817 564. THE FIRING POINT WAS NOT OBSERVED BY UNMOS, BUT THE WPN WAS HEARD COMING FROM A DIRECTION THAT WOULD AGREE WITH THE POSSIBLE FIRING POINT. A DIAGRAM OF THE SUPPOSED WPN IS AT ANNEX B.
3. TO DATE WE HAVE SEEN SEVERAL LARGE PIECES FROM THE WPN INCLUDING 3X 128mm ROCKET BODIES, THE PARTS OF A POSSIBLE AIRCRAFT BOMB FUZE AND 3X LARGE STEEL PLATES THAT COULD POSSIBLY BE FROM THE BOMB CASING OR FROM THE CASING THAT HELD THE WHOLE WPN TOGETHER. DIAGRAMS OF THE ITEMS WE HAVE FOUND ARE AT ANNEX C.

4. FROM BIH SOURCES AFTER THE WPN WAS FIRED THE TIME OF FLIGHT WAS APPROX 20 SECONDS. THE WPN LEFT A TRAIL OF BLACK SMOKE AND WAS SLOW IN FLIGHT.

AFTER THE WPN WAS FIRED THE VEHICLE RETURNED TO THE "CARPET FACTORY" IN ILIDZA BP 824568. THIS IS THE STORAGE SITE FOR A LOT OF BSA VEHICLES INCLUDING M53159 PAKA - NONE OF THE ABOVE IS UNMO CONFIRMED.

THE UNMOS HEARD THE WPN COMING (IT LANDED APPROX 200M FROM THE TEAM LOC) BUT DID NOT SEE IT IN FLIGHT.

WRITTEN BY FLT LT ROWN SI-1 "9"
MO 000 978

Changon

WITNESSED BY CAPT OVERLAND
MO 000 834

Th Overland

CAPT RAZA
MO 000 823

Raza

MAJ DARGHISTANI
MO 000 164

Darghistani

ANNEX A TO
SPECIAL SI-1 REPORT
DATED 10/31/03 APAC

IMPACT SITE DIAGRAM

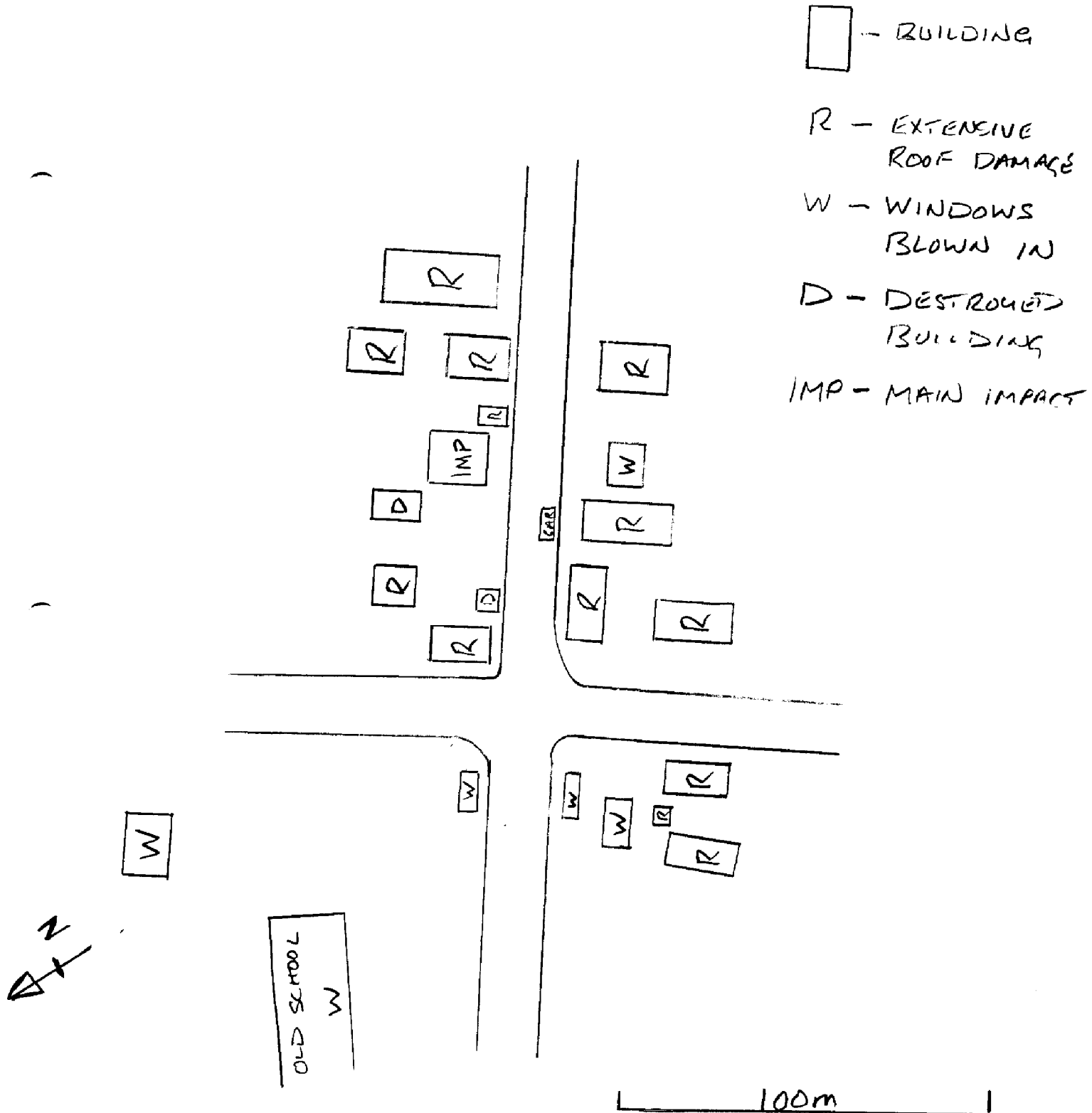

ANNEX B TO
SPECIAL SI-1 REPORT
DATED 10 13 10 13 APR 95

DIAGRAM OF POSSIBLE WPN

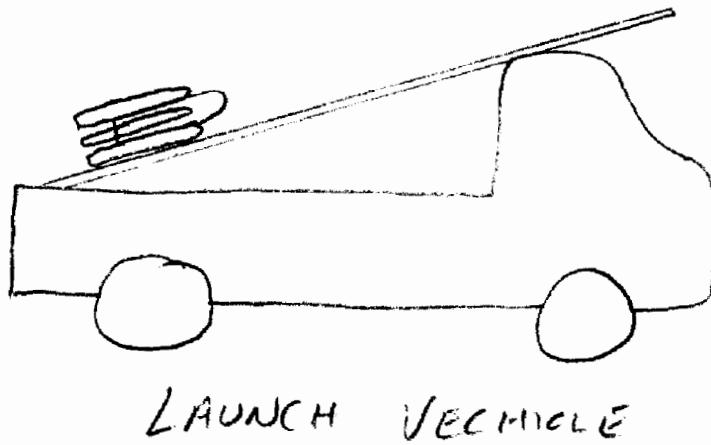
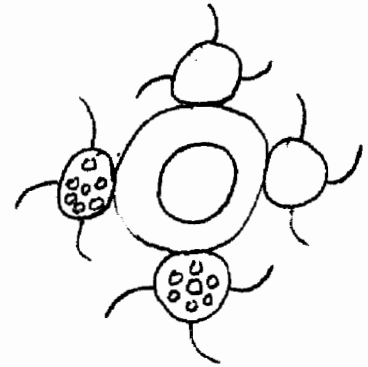
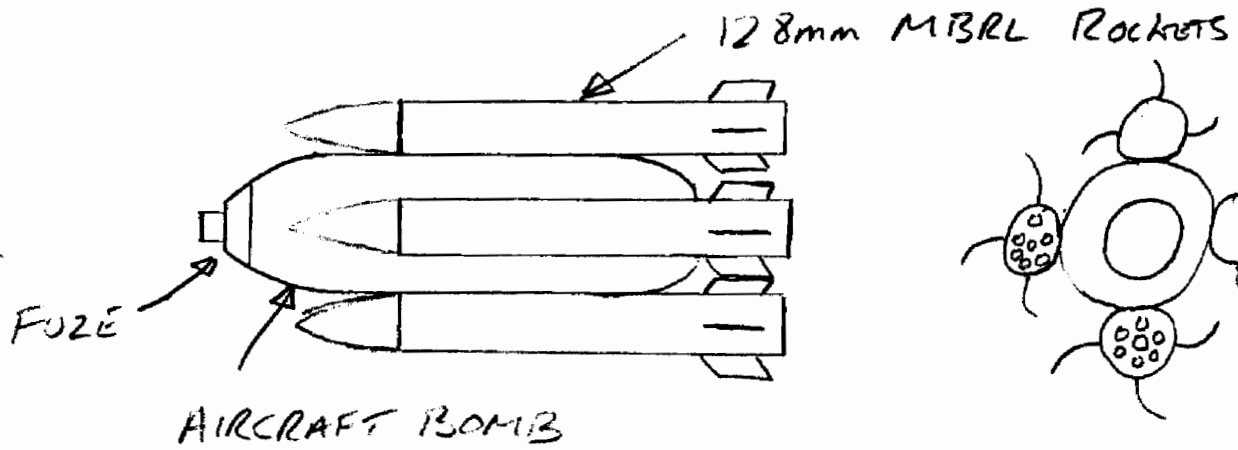

ANNEX C TO
SPECIAL SE-1 REPORT
DATED 101310Z APR 95

DIAGRAMS OF PARTS FOUND

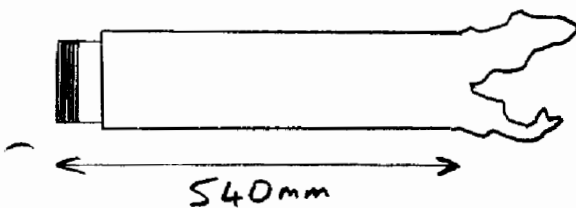
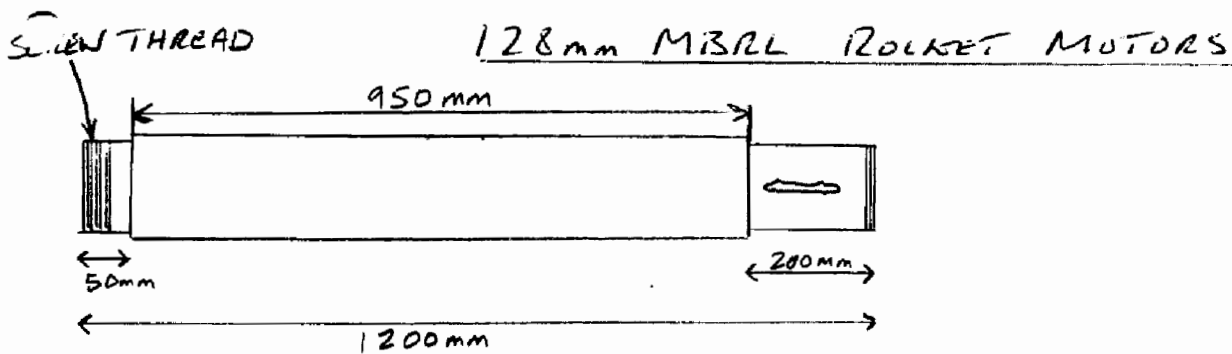
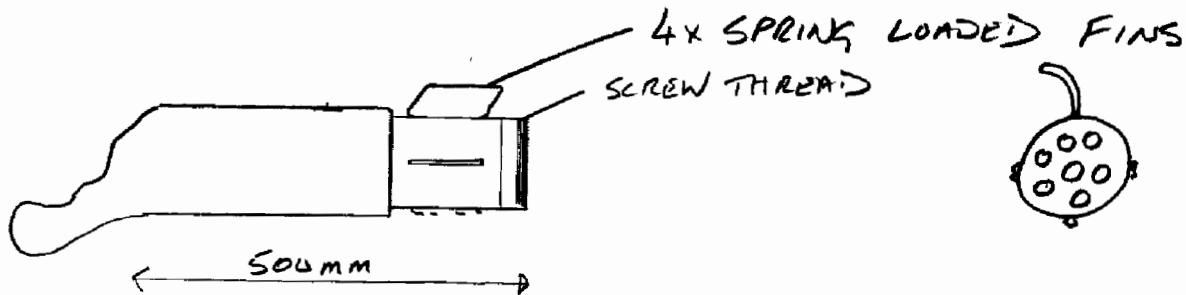

WE HAVE ALSO SEEN OTHER FRAGMENTS WITH MATCHING SCREW THREADS WHICH FIT THE FRONT OF THE ABOVE ROCKET MOTOR BODIES SO WE BELIEVE THAT THE M130L MOTORS HAD WALTHERS.

ON ONE OF THE ROCKET FINS FOUND WERE THE FOLLOWING MARKS - F 41 BH

ANNEX C TO
SPECIAL SI-1 REPORT
DATED 10/31/13 AP/AS

DIAGRAM OF PART FOUND

POSSIBLE AIRCRAFT BOMB FUZE ASSEMBLY:

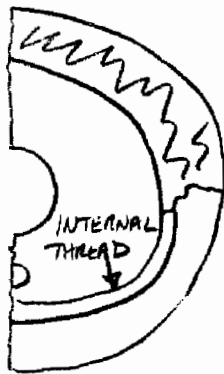
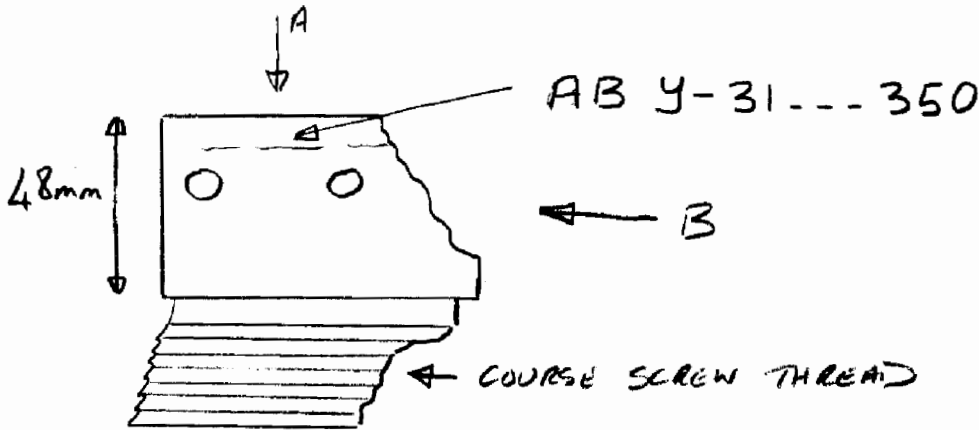

A

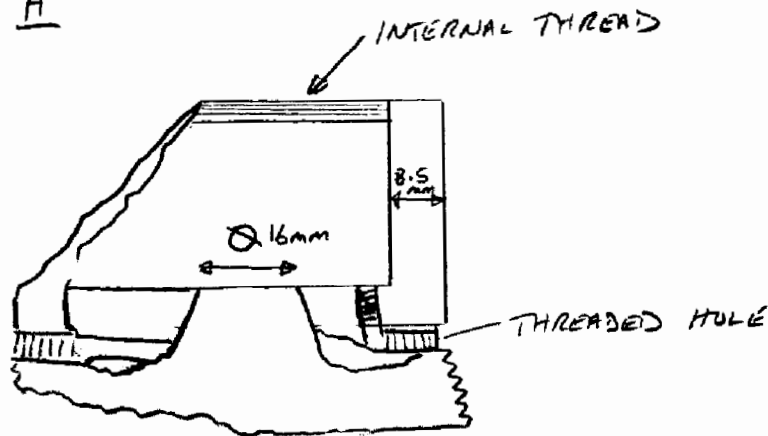

B

THE OUTER THREAD OF THE ABOVE MATCHES THE
 PIECE OF POSSIBLE FUZE HOLDER SUPPLIED.

ANNEX C TO
SPECIAL SI-1 REPORT
DATED 10 13 10 B APR 95

DIAGRAM OF PARTS FOUND

POSSIBLE AIRCRAFT BOMB FUZE HOLDER:

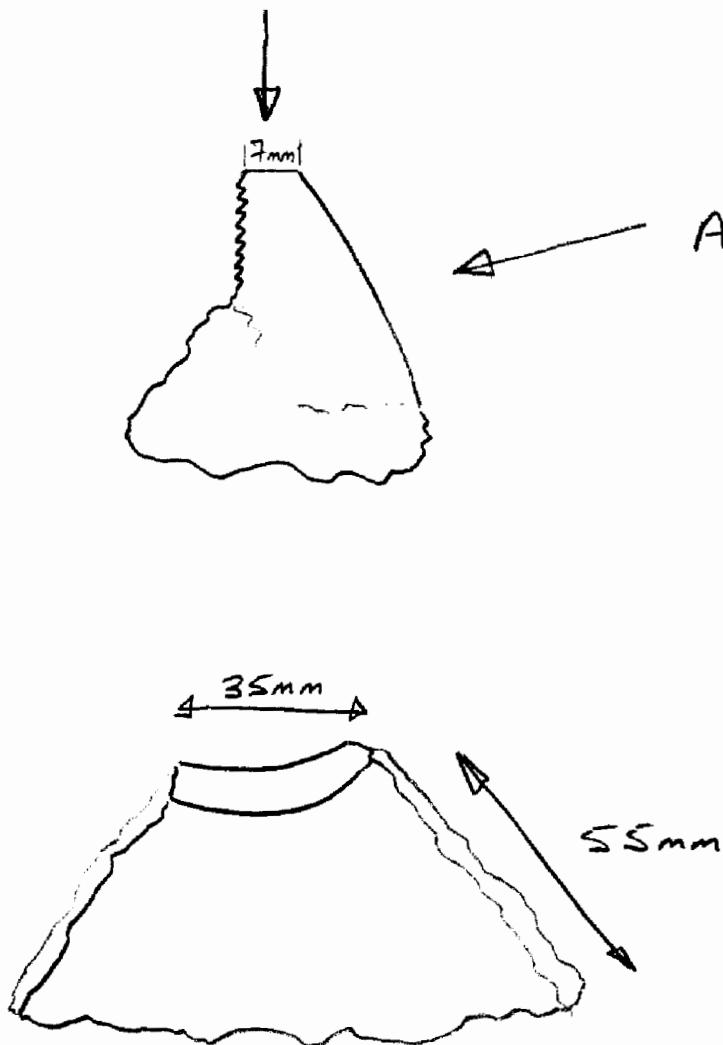

A PIECE OF THE ABOVE ITEM IS PROVIDED.

ANNEX C TO
SPECIAL SI-1 REPORT
DATED 10/31/03 APR 95

DIAGRAM OF PARTS FOUND

POSSIBLE BOMB CASING / OR CASING FOR COMPLETE WPN:

3 x SAME SIZE FRAGMENTS HAVE BEEN SEEN

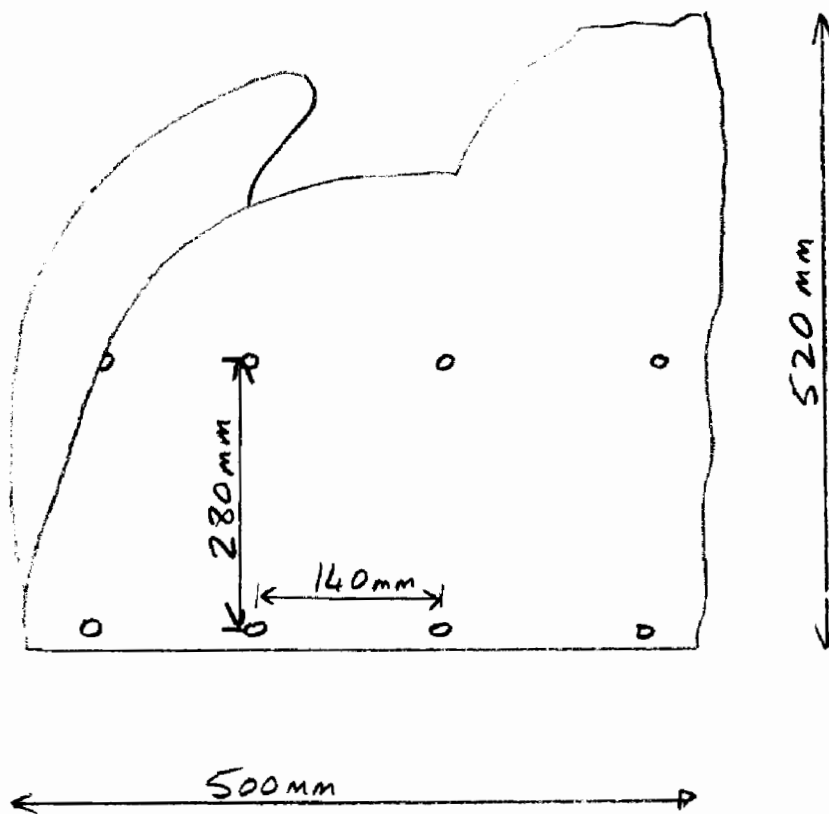

THESE ARE STEEL SHEETS 3mm THICK

IN THE BOLTS HOLES HAVE BEEN NUTS AND BOLTS
 IN SOME OF THEM APPROX 35mm LONG WITH THE
 FOLLOWING MARKINGS ON THE HEADS



Fragments found in Hrasnica

ANNEX TO JSR
UNMO HQ SJV
DATED 19/805 APR 5

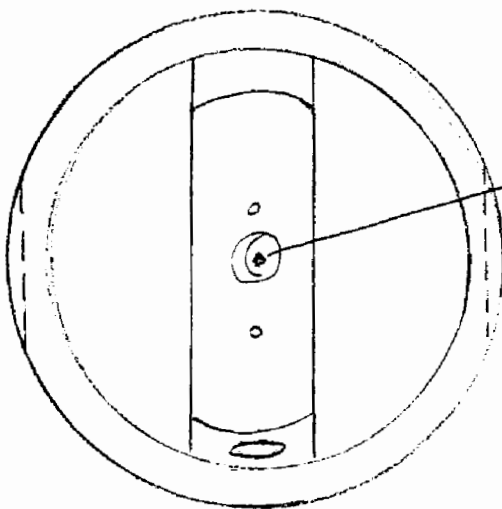
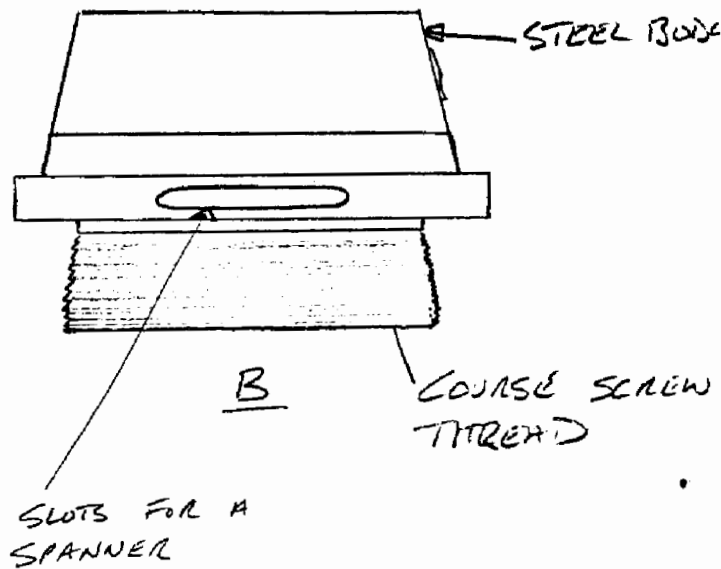
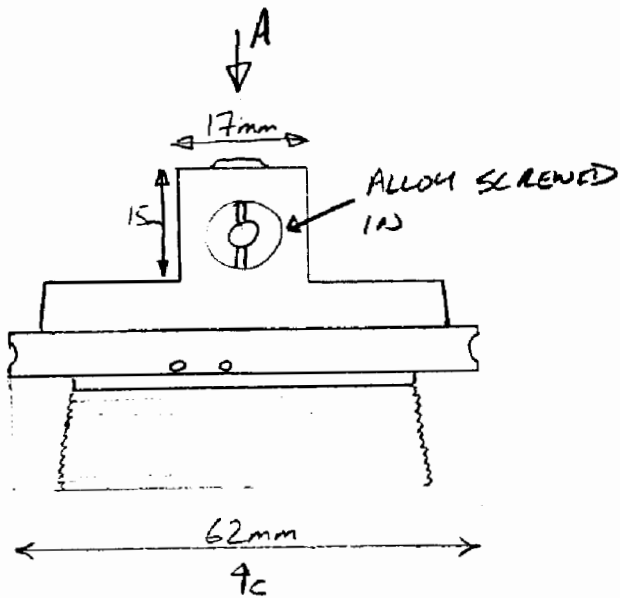

SMALL HOLE THROUGH BODY

SLOTS FOR A SPANNER

* TO SCALE *

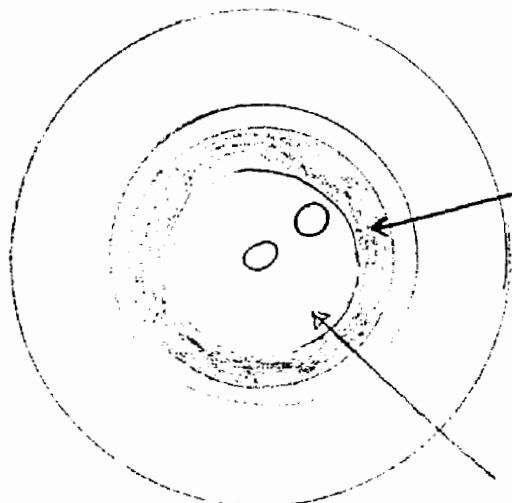

INNER CIRCLE OF BRASS ALLOY

INNER OF BRASS ALLOY



To : G2 BHC
From : UNMO Sector Sarajevo
Capt T. Hansen
OPSO

ANNEX B TO
SPECIAL SI-1 REPORT
DATED 10 13 10 13 APR 96

DIAGRAM OF POSSIBLE WPN

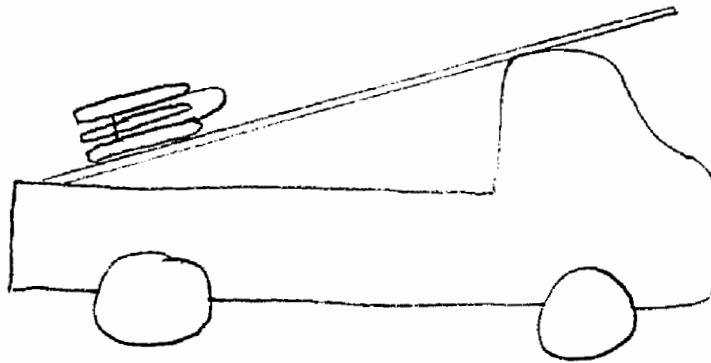
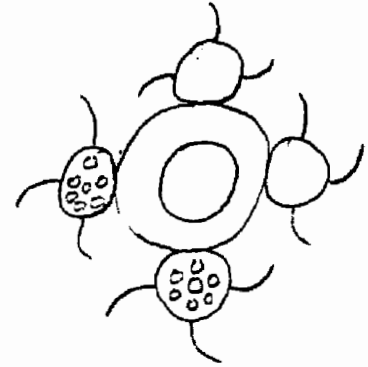
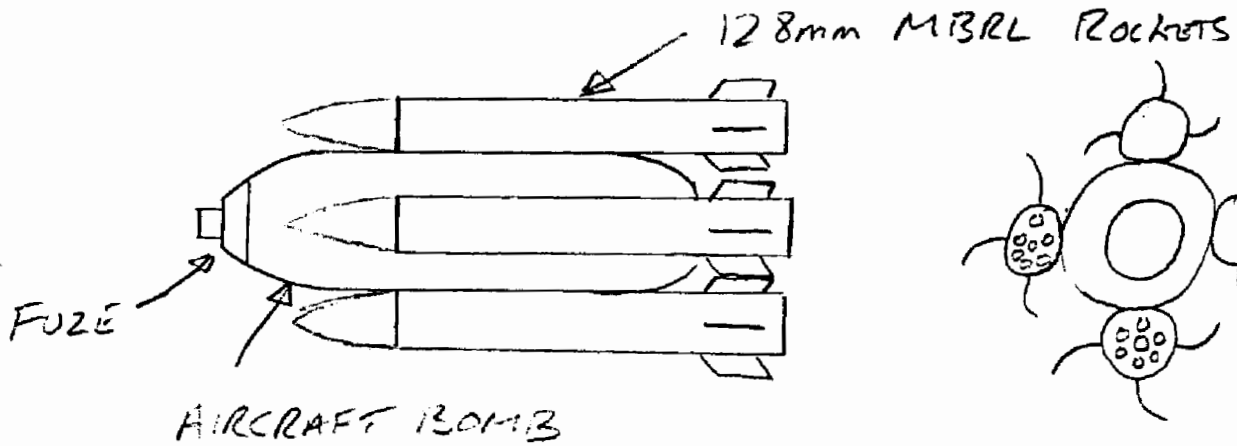

LAUNCH VEHICLE